



Pre-mix beer cooler LIFE 175. Eco-friendly cooler with gas R290, reduced energy consumption and 40% higher performance compared to R404 coolers.

It features a special opening to speed up technical maintenance.

BASE IN ST. STEEL

FEATURES

- COMPRESSOR 3/4 HP
- COOLING CAPACITY 175 LT./HOUR
- POWER 1710 W

SPECIFICATIONS

Power	3/4 HP	Power consumption	649 W
Type of refrigerant gas	R290A	Rated Current	7 A
Rated power(-10°C +45°C)	1710W	Operating temperature allowed	+10°/+43°C
Number of cooling coils	1-8	Max relative humidity allowed	80%
Tank capacity	70Lt.	Weight (unladen static load)	60 Kg.
Ice bank	32Kg.		
Cooling capacity (in +25°C / out -4°C)	175 Lt./hour		
Beverage temperature IN/OUT	+24°C +4°C		
Supply voltage standard frequency	220/240V -50Hz 115V - 60Hzz 220V - 60Hz		

TECHNICAL DRAWINGS

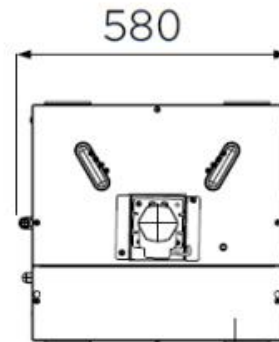
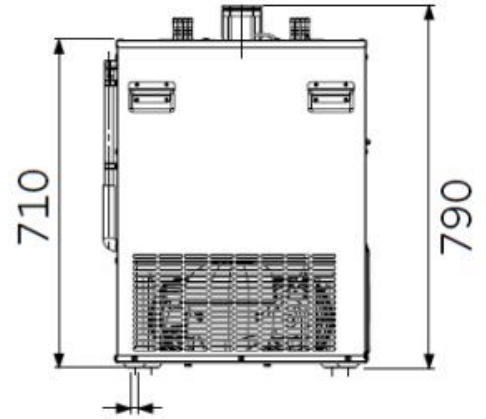
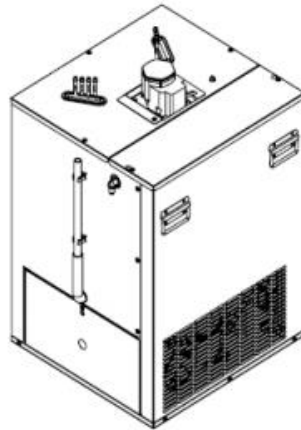
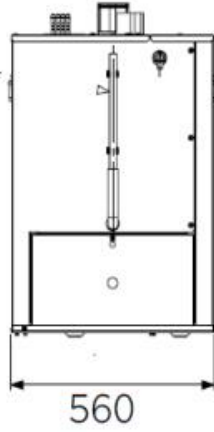

Life 175 Chiller